



Competence in ceramics



GEBR. PFEIFFER
Progress is our tradition



GEBR. PFEIFFER

GEBR. PFEIFFER

Progress is our tradition

Gebr. Pfeiffer looks back on a long and successful history that is based on high-quality products, closeness to the customer and an international standing. Even in an environment undergoing fast changes we remain loyal to these standards. That is why our company and its employees will shape the future.

Since our foundation in 1864 we have always participated in the development of modern process technology for grinding, separating, drying, hydrating and calcining.

With more than 450 employees, our center of competence in Kaiserslautern as well as our subsidiaries in the United States and India are active all over the world, supported by an extensive network of cooperations and representations.



Our success is the result of a wide product range, a modern test station, in-house workshops with a high vertical capacity and an extensive store of experience especially with the cement, lime, gypsum and ceramics industries.

We regard the finding of customized systems that meet your special requirements as our most important task.

We ensure a long service life for our plants and machines by establishing long-lasting cooperations in a spirit of partnership to the benefit of a high-quality finished product, safe plant operation, economic viability and technical progress.

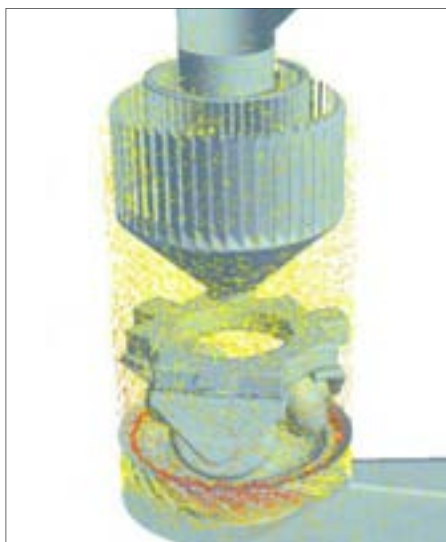



Dry processing – the economical solution

For thousands of years mankind has been accompanied by ceramics. It is essential not only to everyday life but also to the building trade.

Over the last century application in engineering has become ever more significant. Today the ceramics industry covers the most diverse product ranges, e.g. bricks and tiles, roofing tiles, ducts, tableware and sanitary ware, refractories and technical ceramics, all made from natural raw materials such as clay, kaolin, quartz and feldspar.

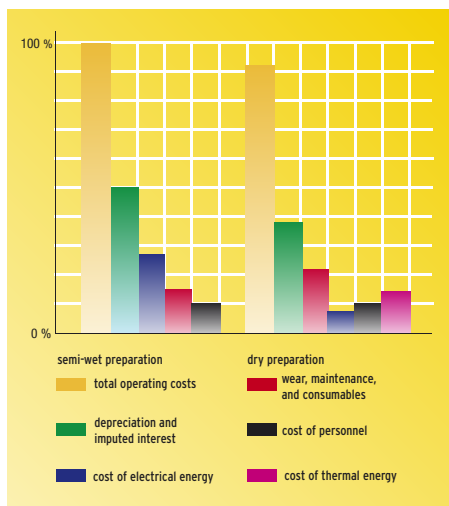

For this reason raw material processing ranks high in ceramics industry. Homogeneity and fineness as well as the elimination or fine-grinding of impurities, to render them harmless, influence both the further production process and the quality of the burnt finished product. Increasing quality requirements and cost pressure demand effective processes. Here, dry processing as a continuous and automated process points the way forward.

We design and manufacture for you complete processing plants or offer you from our extensive manufacturing program individual machines for the solution of your special problem.

Pfeiffer has set standards in the dry processing of ceramic raw materials. The ceramics industry has confidence in us.

We are competent in

- grinding
- drying
- separating

The PFEIFFER product range comprises:

- **the PFEIFFER MPS vertical roller mill**9
ideal for the combined grinding and drying
- **the PFEIFFER MRD/MRE ball mill** 10
ideal for the fine-grinding of highly abrasive raw materials
- **the PFEIFFER distribution table air separator**.....11
type SUT with constant speed
type SUV with variable speed
- **the PFEIFFER high-efficiency classifier**11
type SLV with variable speed
- **the PFEIFFER TRT Triplex dryer**13
the space-saving dryer for ceramic raw materials of all usual grain sizes

1

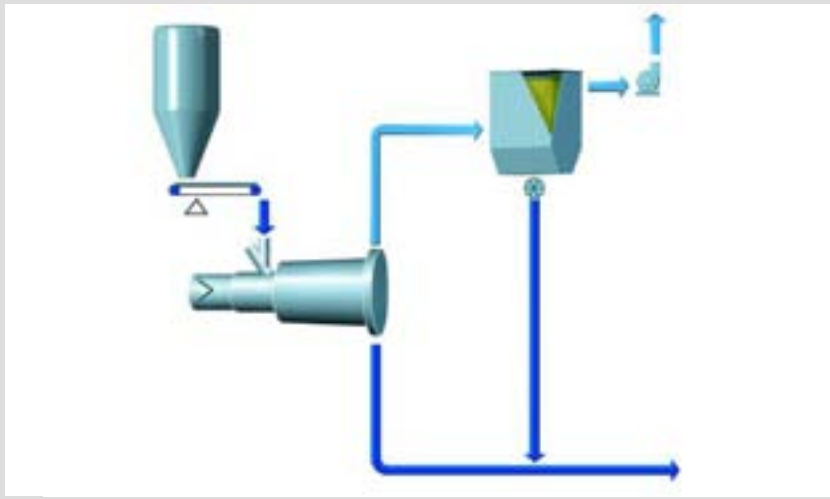

2

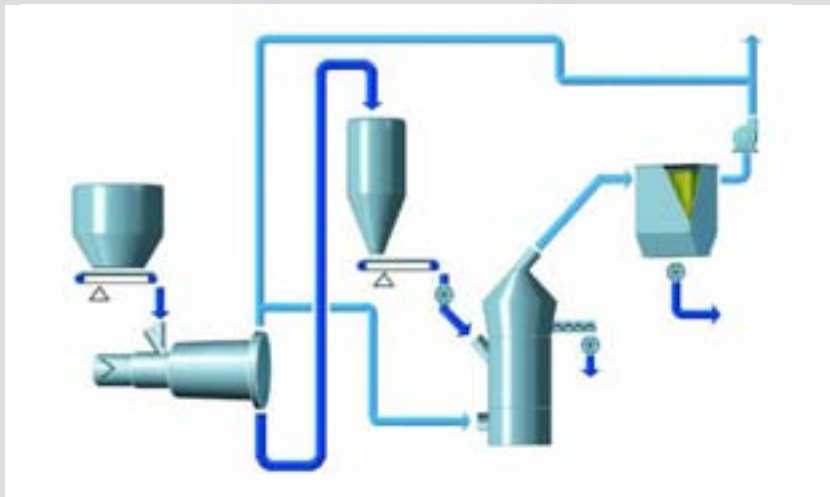

3

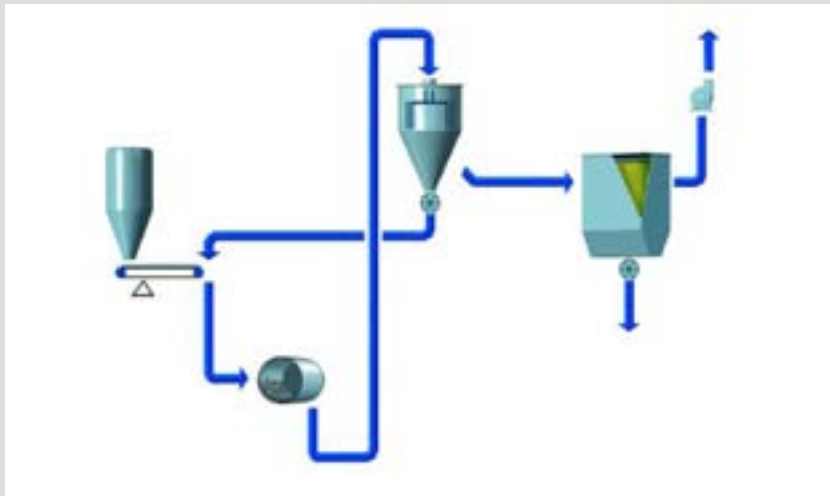

Our machines and processes for the ceramics industry

❶ Drying

In PFEIFFER Triplex dryers, lumpy ceramic raw materials such as clay, kaolin, feldspar or quartz are dried to the required residual moisture.

The materials obtained this way can be processed further either in grinding plants or in separating plants. Also they can be directly forwarded to the plastic shaping.

❷ Combined grinding and drying

In PFEIFFER MPS vertical roller mills, lumpy ceramic materials with a low to medium abrasiveness are ground, separated and dried. The finished product fineness can be set within wide limits from 0.02 to 0.5 mm. If required, any foreign material contained in the feed material can be separated and removed from the system during the process. With feed moistures exceeding 12 % the material is pre-dried in a Triplex dryer for economical reasons.

With coarse and fine ceramics the ground, pulverized materials are used as basic materials for the manufacture of ceramic working masses and mixtures. During grinding the raw materials, which themselves are not entirely homogenous and have - mostly for geological reasons - different chemical and physical properties, are homogenized.

❸ Grinding of hard materials

Lumpy and hard ceramic feed materials with a high abrasiveness such as quartz, feldspar, sinter magnesite, bauxite or fireclay, are fine-processed in circuit with ball mills and separators or coarse-processed in several separating stages. The fineness of the finished products can be set within wide limits from 0.01 to 0.5 mm. With feed moistures exceeding 2 % here, too, the material is pre-dried in a Triplex dryer.

The ground finished products are used in all fields of the ceramics industry. During grinding the raw materials which themselves are not entirely homogenous and have - mostly for geological reasons - different chemical and physical properties, are homogenized.

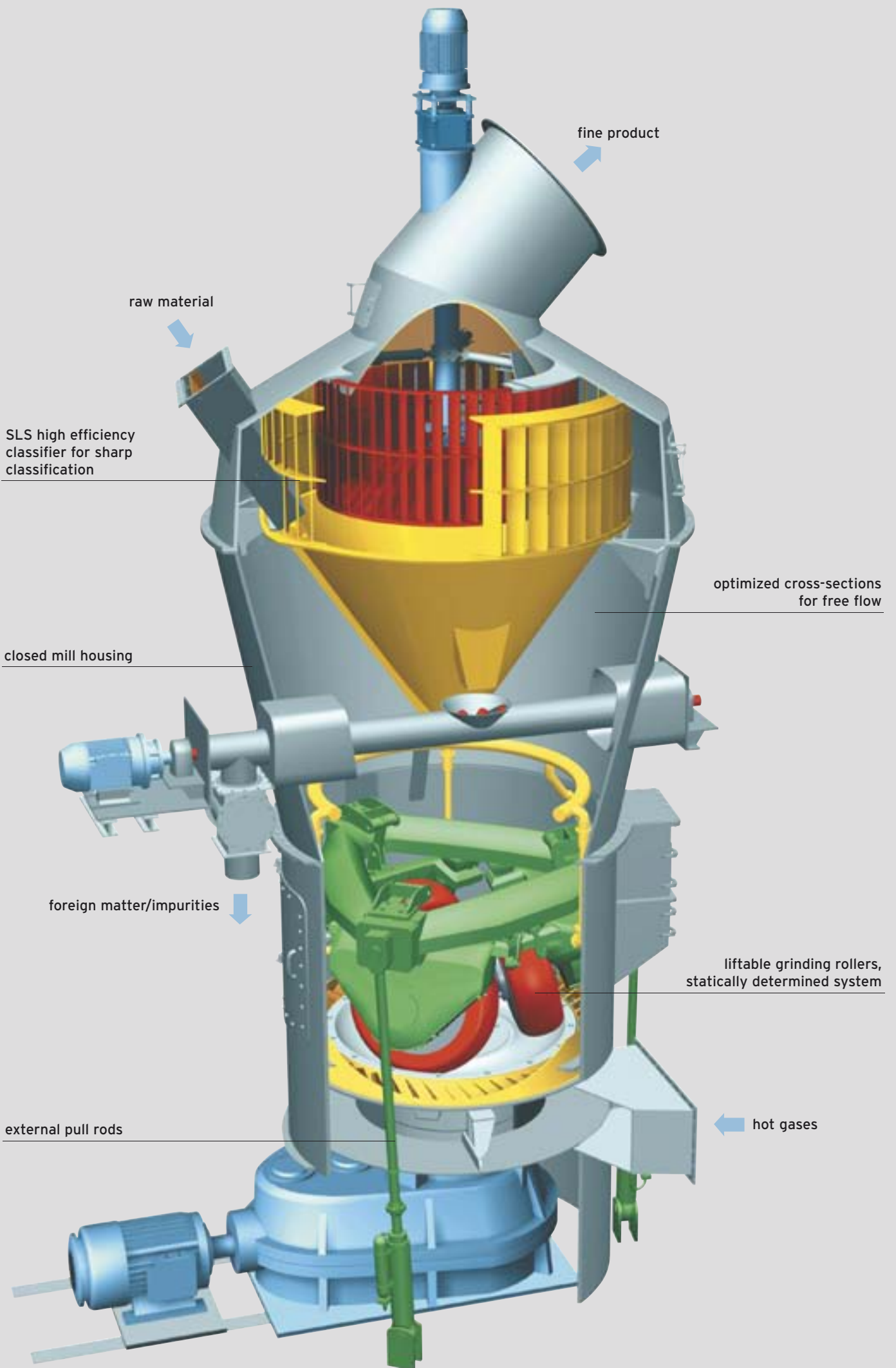

fine product

raw material

SLS high efficiency classifier for sharp classification

optimized cross-sections for free flow

closed mill housing

foreign matter/impurities

liftable grinding rollers, statically determined system

external pull rods

hot gases

The PFEIFFER MPS vertical roller mill – the optimum machine for comminution

The solution to your problem

Grinding-drying of clay, kaolin, limestone, basalt, granite, feldspar, etc

throughput rate	3 - 100 t/h
target fineness	20 - 500 μm
feed size	10 - 60 mm
feed moisture	pit moisture
target moisture	< 1 % H ₂ O

extraction of foreign matter with clay raw materials

The working principle

Three stationary grinding rollers roll on a slowly rotating grinding table. The material is drawn in between grinding rollers and grinding track and ground by pressure and shear. The compression force required for the comminution of the material is generated by a hydropneumatic tensioning system.

The material is ground and conveyed by centrifugal force towards the stationary nozzle ring. Gases (air or hot gases) flowing up through the nozzle ring mix with the material and carry it up to the classifier. In the separating zone a rotating separating wheel separates the ground and dried material into fine finished product and grits.

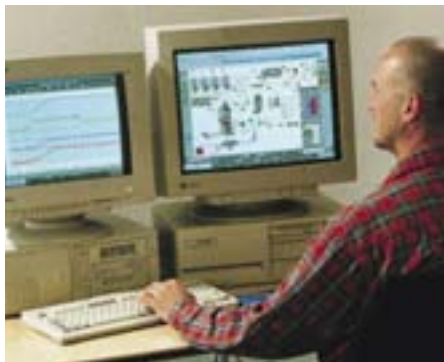

The grits fall back into the center of the grinding zone. The finished product leaves the classifier together with the gas stream and is separated in downstream cyclones or a filter unit.

The advantages

Low investment costs

MPS mills require few ancillary machines, no or little walled-in space, they operate dust-free and have a low noise level.

Low electric power consumption

The grinding principle and the high-efficiency classifier reduce the electric power consumption by up to 40 % compared with conventional ball mills.

Optimum utilization of process heat

MPS vertical roller mills allow an optimum utilization of the thermal energy of low-temperature process gases.

Maximum availability

Low specific wear rates, high-quality wear materials and progressive repair concepts reduce downtimes of MPS vertical roller mills to a minimum.

Favorable control behavior

High drying capacity, short retention times, and remote control of the grinding pressure and the speed of the separating wheel allow MPS vertical roller mills to be operated fully automatically even with fluctuating raw material qualities.

The PFEIFFER ball mills

The solution to your problem

Grinding of highly-abrasive hard materials

throughput rate	1 - 50 t/h
target fineness degree	0.01 - 5 mm
feed size	2 - 30 mm

The working principle

The material is fed into the ball mill through the neck bearing journal. Grinding balls grind it by impact and friction.

The ground material leaves the mill either through discharge slots arranged around the mill tube, through a discharge diaphragm or according to the overflow principle through the neck bearing journal at the end of the mill tube.

Design and setting of discharge slots and discharge diaphragm define the grain size distribution of the ground material.

With circuit operation the target fineness can be set at the separator or, in case of coarse grinding with a downstream screening machine, by selecting a certain mesh width.

Ball mill types

MRD	ball mill with center discharge
MRE	ball mill with end discharge
MKS	screen ball mill
MKF	ball mill with grinding beam

Fine-grinding is generally effected in mills of the MRD and MRE series, whereas coarse grinding is effected in mills of the MKS and MKF series.

If required metal attrition due to wear in the grinding and separating zone can largely be avoided with a ceramic lining applied to mill and separator and with grinding bodies made of Al_2O_3 or flintstone. The separators can also be lined with polyurethane.

The advantages

Low electric power consumption

Fine material particles cannot be ground too finely due to a short grinding track and an adjustable retention time.

Adjustable grain size distribution

With gravity discharge mills, product fineness and grain size distribution are adjustable by a variation of the discharge slots.

Maximum availability

Plain, robust design, wear-resistant lining, low maintenance.

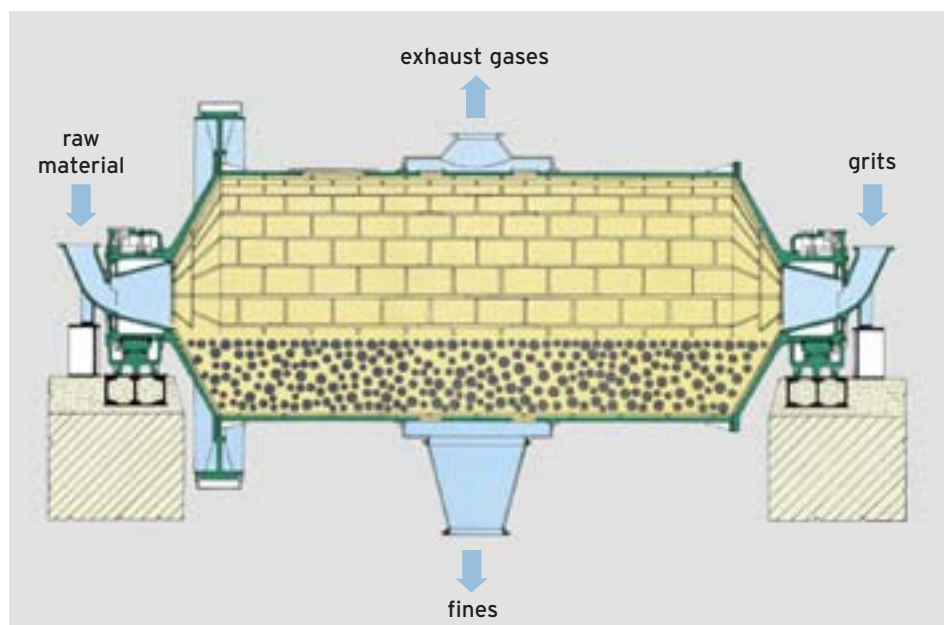

The PFEIFFER separators

The solution to your problem

Separators for circuit operation with mills and for grain sizing in the fine particle range

The distribution table air separator type SUT with constant speed

The cost-effective separator for the production of primarily one target fineness degree, typical target fineness degree 90 - 200 μm .

The distribution table air separator type SUV with variable speed

Your solution when it comes to the production of several target fineness degrees.

The high-efficiency separator type SLV with variable speed

For ultra-sharp separation and the production of high fineness degrees
target fineness 10 - 90 μm
feed rate 1 - 200 t/h

The working principle

An air stream transports the material into the separating zone where it is separated into a fine product and a coarse product. The coarse product is always discharged through a cone, for example for further processing. With the SUT and SUV series the fine

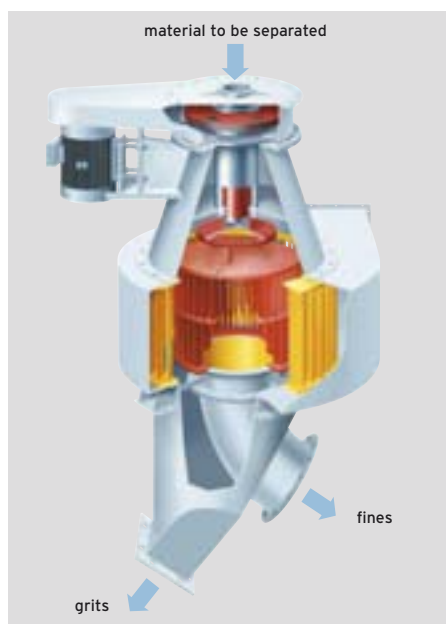

PFEIFFER SLV high-efficiency separator

product is discharged through an integrated cone, with the SLV series it is separated in a downstream cyclone or filter.

The advantages

Sharp separation

Uniform product distribution in the separating zone due to a central material infeed; pre-separation and post-separation as a result of an optimum arrangement of the louvre.

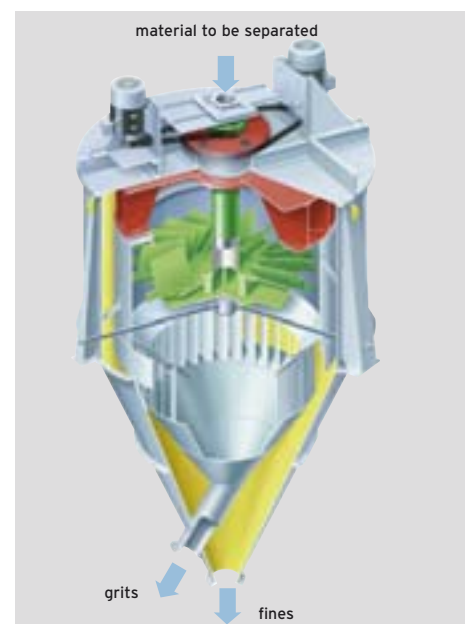

PFEIFFER SUV distribution table air separator

Many and diverse applications

All separators can be used for separation in one passage or in circuit operation with a mill.

No need for dust collection equipment

All distribution table air separators can be operated without dust collection equipment.

Long service life

Special linings protect our separators from wear. We can offer partial or complete linings made of steel, rubber, synthetic or ceramic materials, depending on the type and abrasiveness of the processed material.

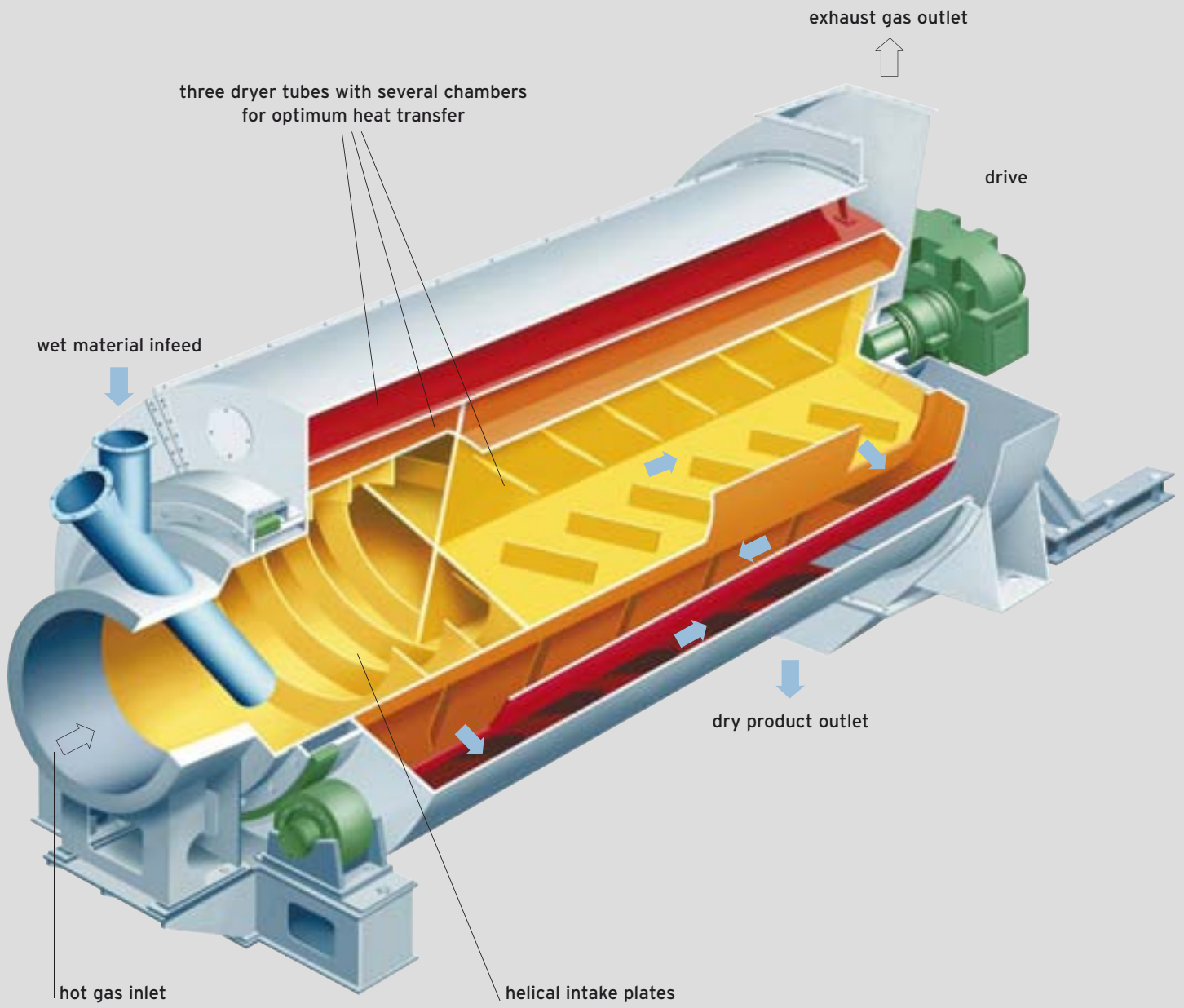

The PFEIFFER Triplex dryer

The solution to your problem

Drying or pre-drying of ceramic raw materials

finished product rate	1 - 200 t/h
feed size	150 mm max
feed moisture	all usual feed moistures
residual moisture	0.1 % max

The working principle

The Triplex dryer type TRT operates on the uniflow principle, i.e. material and hot gases flow in the same direction and pass through the concentric dryer tubes from the center outwards.

The material to be dried is fed into the innermost tube, it passes through the dryer and is discharged through double pendulum flaps fitted to the dust jacket.

The residual moisture of the dried material is controlled by a regulation of exhaust gas temperature and retention time of the material in the dryer.

The advantages

The hot gas is produced in a combustion chamber. Solid, fluid or gaseous fuels can be used for combustion. A utilization of process gases is possible as well.

The dryer exhaust gases are dedusted in a filter.

Low space requirement

As a consequence of the short design and the concentric arrangement of the dryer tubes the investment cost for buildings and foundations is low.

Short dryer start-up and shut-down times

No ceramic lining is required, the dryer is made of temperature-resistant steel plates.



TRT Triplex dryer with hot gas generator

Careful material treatment

The material is treated with care, because of the uniflow principle it will not overheat.

Low thermal energy consumption

The small dryer surface and the uniflow principle result in a very low heat loss by radiation.

PFEIFFER machines and industrial plants



PFEIFFER services

You can always count on us

Test station

In our test station raw materials are tested for their processing qualities, and in our laboratories these raw materials are characterized by taking all the relevant norms/specifications and standards into account.

For these tests pilot plants with machines from our manufacturing program are available for throughput rates from 0.5 to 10 t/h. The results of the tests serve as a basis for the selection of the suitable process for a given application and for the machine and process dimensioning.



Spare parts service

Original spare parts guarantee that your plant will operate economically even many years after its erection. Take advice from our experienced engineers. Our electronic wear analysis for the grinding elements of the MPS mill records the actual wear progress and allows a selective spare parts inventory and maintenance.

Erection and commissioning

Experienced engineers and supervisors are available for erection and commissioning and for the training of your operating and maintenance personnel.

Consultation

We are competent in designing and planning not only new plants but also plant conversions, the upgrading and modernization of existing plants, maintenance and repair, the selection of suitable wear materials and in answering all process related questions.

Manufacture

We have our own mechanical workshops and foundry. All phases of our product manufacture are carefully planned. The quality of our products is systematically supervised and documented pursuant to the quality management system of DIN ISO 9001.





GEBR. PFEIFFER

Progress is our tradition

Gebr. Pfeiffer SE
Barbarossastraße 50-54
67655 Kaiserslautern/Germany
Phone: +49 631 4161 0
Fax: +49 631 4161 290
E-mail: kv-p@gpse.de
Internet: www.gpse.de