



Competence in cement



GEBR. PFEIFFER
Progress is our tradition



GEBR. PFEIFFER

GEBR. PFEIFFER

Progress is our tradition

Gebr. Pfeiffer has a long and successful history founded on high quality products, closeness to the customer and an international standing. Even in an environment undergoing fast changes, we remain loyal to these standards. This is how our company and employees will shape the future.

Since the company's foundation in 1864, we have always been significantly involved in the development of modern process technologies for the sectors grinding, separating, drying, hydrating, and calcining.

With more than 450 employees, our center of competence in Kaiserslautern as well as our subsidiaries in the United States and India are active all over the world, profiting from an extensive network of cooperations and representations.



The keys to our success are a wide product range, a modern test station, vast design and R&D capacities and inhouse workshops with a high vertical capacity, all working with an extensive



store of experience especially in the cement, lime, gypsum, and ceramics industries.

Our ultimate ambition is to develop tailor made problem solutions meeting the customer's requirements. By establishing long-lasting, reliable relationships with our customers to the benefit of high quality finished products, plant availability, economic efficiency, and technical progress, we ensure a long service life for our machines and plants.

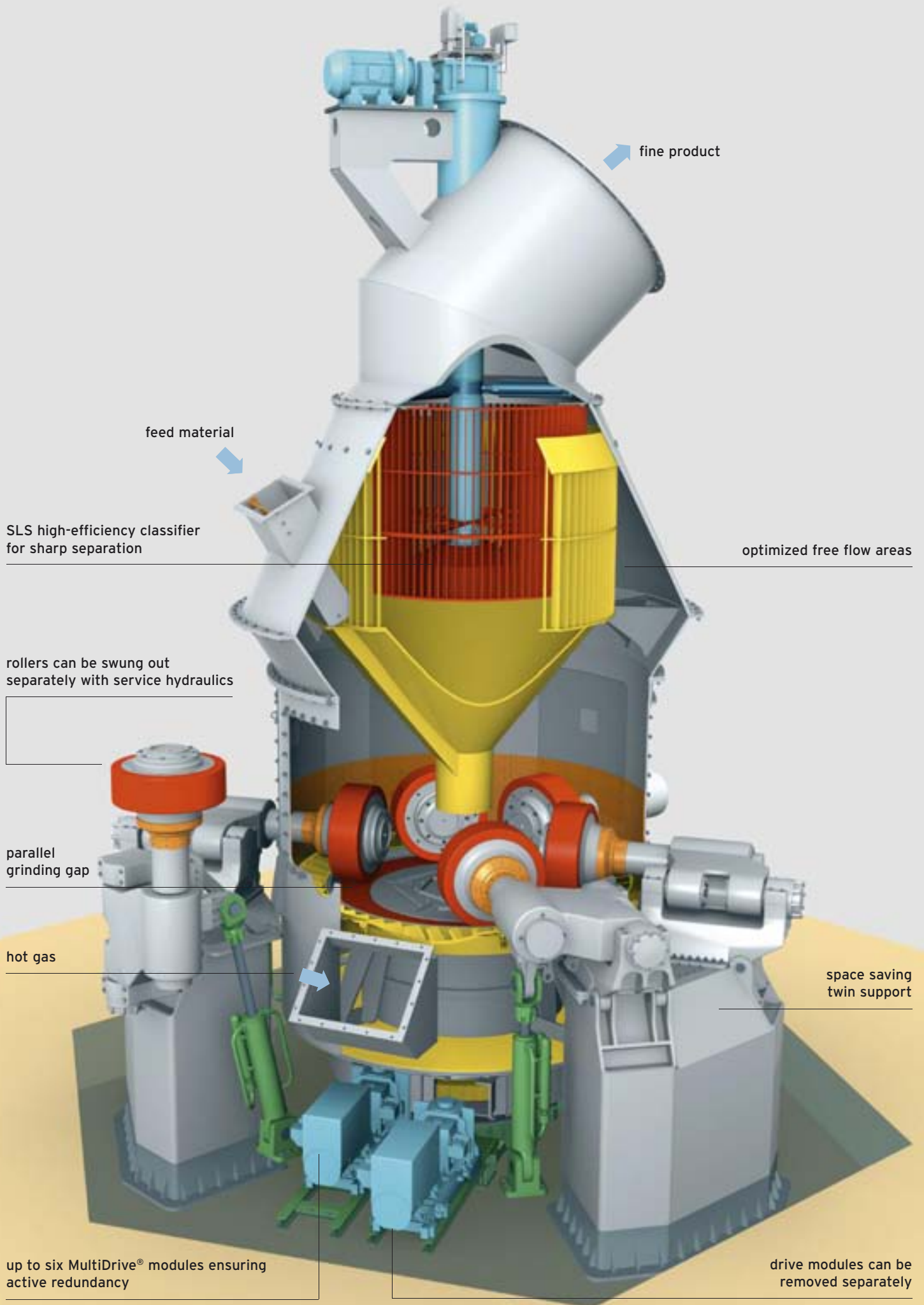

fine product

feed material

SLS high-efficiency classifier for sharp separation

optimized free flow areas

rollers can be swung out separately with service hydraulics

parallel grinding gap

hot gas

space saving twin support

up to six MultiDrive® modules ensuring active redundancy

drive modules can be removed separately

PFEIFFER MVR mill - the optimum machine for grinding high throughput rates

The solution to your problem

In the cement industry, MVR roller mills are used for grinding cement raw material, cement clinker, granulated blast-furnace slag, and pozzolana. Such bulk materials differ considerably in terms of grindability and abrasiveness. The capacities of cement production lines vary within wide limits to suit individual requirements. Due to its design, the MVR roller mill is specially suited for high and very high throughput rates.

The working principle

Up to six stationary grinding rollers roll on a rotating grinding track. Drawn in between the rollers and track, the feed material is ground by pressure and shear. The compression forces required for comminution are produced by a roller arm and pivot bearing along with a hydropneumatic tension system.

The ground material is conveyed by centrifugal forces towards the stationary nozzle ring. Gases (air or hot gas) flowing up through the nozzle ring carry the ground and dried material to the classifier where it is separated into grits and fines by the rotor. The grits fall back into the center of the grinding area.

The finished product leaves the classifier with the gas flow for separation in the downstream cyclones or filter.



The advantages

MultiDrive®

The MultiDrive® system consists of up to six identical drive modules ensuring active redundancy of the drive system. The MultiDrive® design allows an optimum speed of the mill and thus highest flexibility.

Active redundancy of the grinding roller system

Up to six grinding rollers, which can be swung out separately with their special suspension system, and the grinding plate form a grinding gap that remains parallel in any operating point, ensuring a uniform compaction of the material to be ground. This concept creates an active redundancy as in the MultiDrive® system.

Low capital cost

MVR mills require few ancillaries, no or little building volume, their operation is dust free and they have a low noise level.

Low electric power consumption

The grinding principle and high-efficiency classifier reduce electric power consumption by up to 40 % as compared with conventional ball mills.

Optimum utilization of process heat

MVR roller mills allow an optimum utilization of the thermal energy of process gases.

Maximum availability

Thanks to low specific wear rates, high quality wear materials, and modern repair methods, the maintenance downtime of MVR roller mills is reduced to a minimum.

Favorable control behavior

High drying capacity, short retention time, and remote control of grinding pressure and rotor speed allow a fully automatic operation of the MVR roller mill even with varying raw material qualities.



GEOR. PFEIFFER AG

30408

Raw material grinding on the Pfeiffer MVR roller mill

The solution to your problem

throughput rates of up to **1,400 t/h**
 drive power of up to **12,000 kW**
 target fineness 60 - 100 μm
 residual moisture < 0.5 %

Combined grinding and drying of raw materials with moisture rates of more than 20 %, all in one unit.
 Feed sizes of up to 100 mm, hence no secondary crushing required.

MVR roller mill

- short change-over time from direct to compound operation
- modular design, i.e. optimum combination of housing cross-sections and geometry of grinding elements
- optimum, symmetric design of wear parts and modern maintenance concepts
- good partial load behavior
- low capital cost
- low electric energy consumption
- highest availability
- favorable control behavior

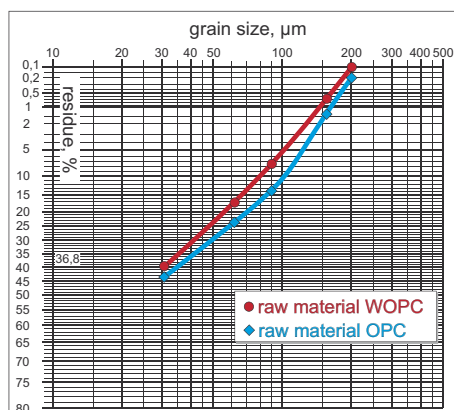
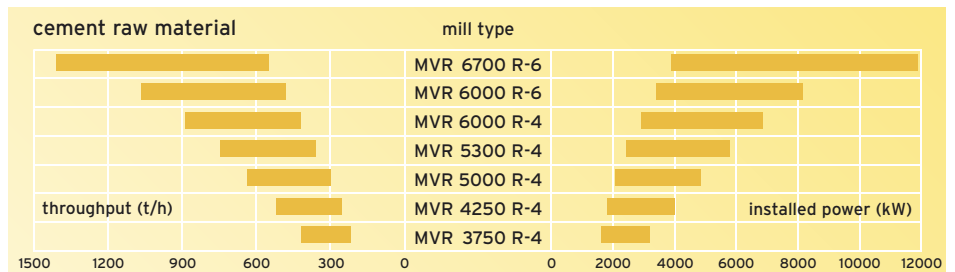
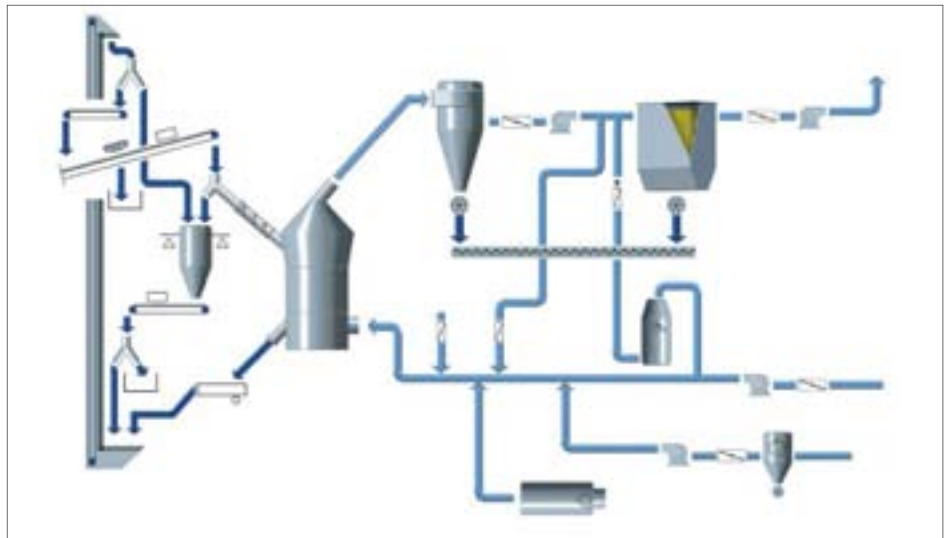



Grinding of granulated blast-furnace slag and cement on the Pfeiffer MVR roller mill

The solution to your problem

throughput rates of up to **550 t/h**
 drive power of up to **12,000 kW**
 target fineness 2000 - 6000 cm²/g

Common or separate grinding of main cement components.
 Combined grinding and drying of main cement components with moisture rates of more than 20 %, all in one unit.
 Production of various cement qualities in one mill. Products in line with standards and market requirements.

MVR roller mill

- process and wear protection designed to suit raw material
- practically no transitional products when changing over
- utilization of process heat
- optimum, symmetric design of wear parts and modern maintenance concepts
- low capital cost
- low electric energy consumption
- highest availability
- favorable control behavior

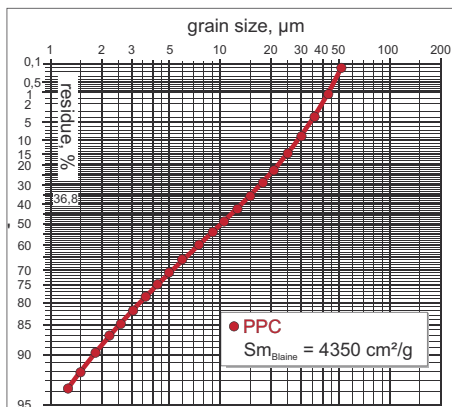
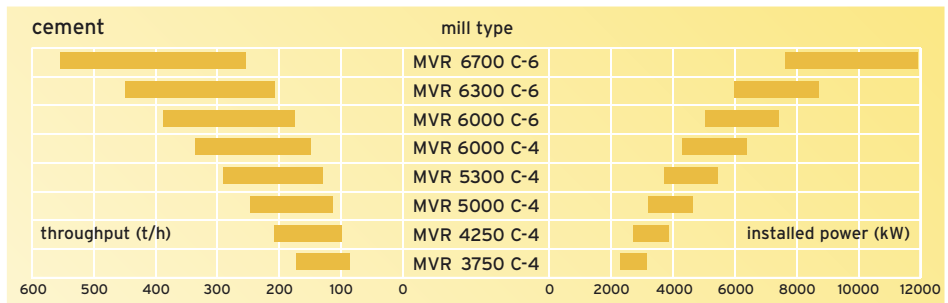
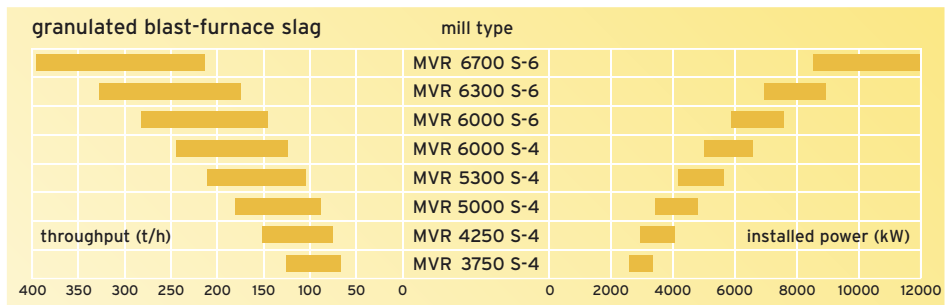
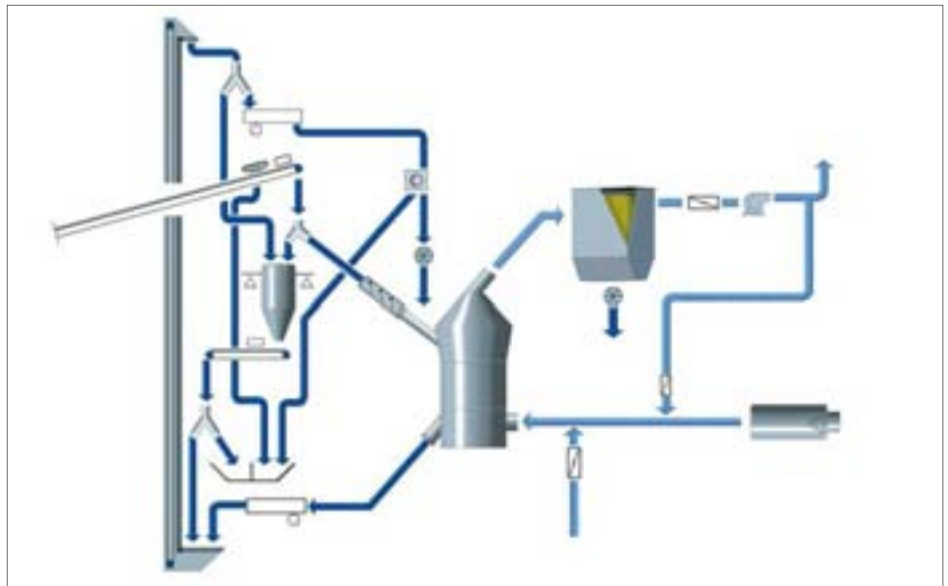

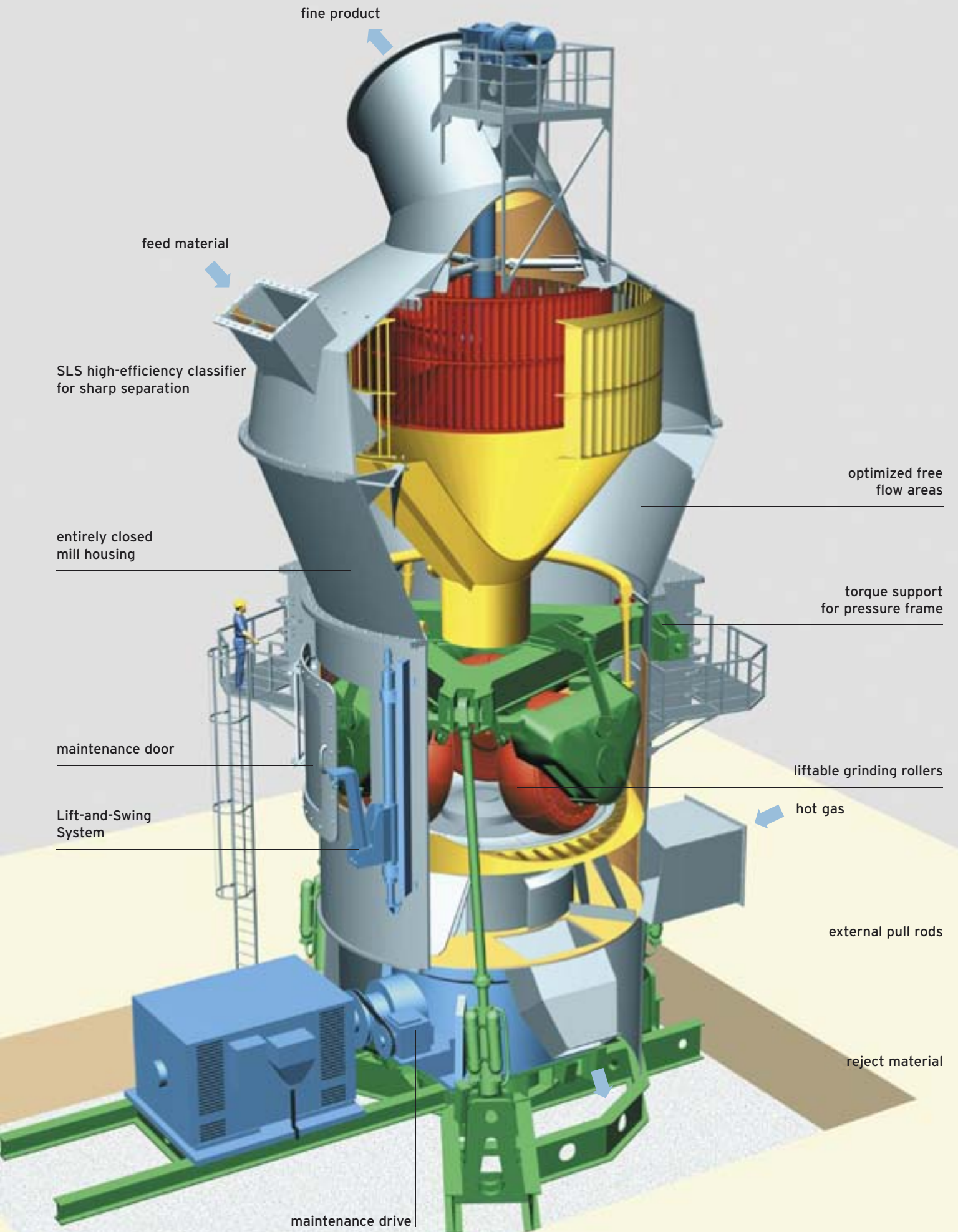

PFEIFFER MPS mill - the proven system for comminution

The solution to your problem

In the cement industry, MPS roller mills are used for grinding cement raw material, coal, cement clinker, granulated blast-furnace slag, and pozzolana. Such bulk materials differ considerably in terms of grindability and abrasiveness. The capacities of cement production lines vary within wide limits to suit individual requirements. Due to its design, the MPS roller mill is specially suited for small and medium throughput rates.

The working principle

Three stationary grinding rollers roll on a rotating grinding track. Drawn in between the rollers and track, the feed material is ground by pressure and shear. The compression forces required for comminution are produced by a hydropneumatic tension system.

The ground material is conveyed by centrifugal forces towards the stationary nozzle ring. Gases (air or hot gas) flowing up through the nozzle ring carry the ground and dried material to the classifier where it is separated into grits and fines by the rotor. The grits fall back into the center of the grinding area.



The finished product leaves the classifier with the gas flow for separation in the downstream cyclones or filter.

The advantages

Low capital cost

MPS mills require few ancillaries, no or little building volume, their operation is dust free and they have a low noise level.

Low electric power consumption

The grinding principle and high-efficiency classifier reduce electric power consumption by up to 40 % as compared with conventional ball mills.

Optimum utilization of process heat

MPS roller mills allow an optimum utilization of the thermal energy of process gases.

Maximum availability

Thanks to low specific wear rates, high quality wear materials, and modern repair methods, the maintenance downtime of MPS roller mills is reduced to a minimum.

Favorable control behavior

High drying capacity, short retention time, and remote control of grinding pressure and rotor speed allow a fully automatic operation of the MPS roller mill even with varying raw material qualities.





Grinding of granulated blast-furnace slag and cement on the Pfeiffer MPS roller mill

The solution to your problem

throughput rates 10 - 300 t/h
target fineness 2000 - 6000 cm²/g

Common or separate grinding of main cement components.
Combined grinding and drying of main cement components with moisture rates of more than 20 %, all in one unit.
Production of various cement qualities in one mill. Products in line with standards and market requirements.

MPS roller mill

- process and wear protection designed to suit raw material
- practically no transitional products when changing over
- utilization of process heat
- optimum, symmetric design of wear parts and modern maintenance concepts
- low capital cost
- low electric energy consumption
- highest availability
- favorable control behavior

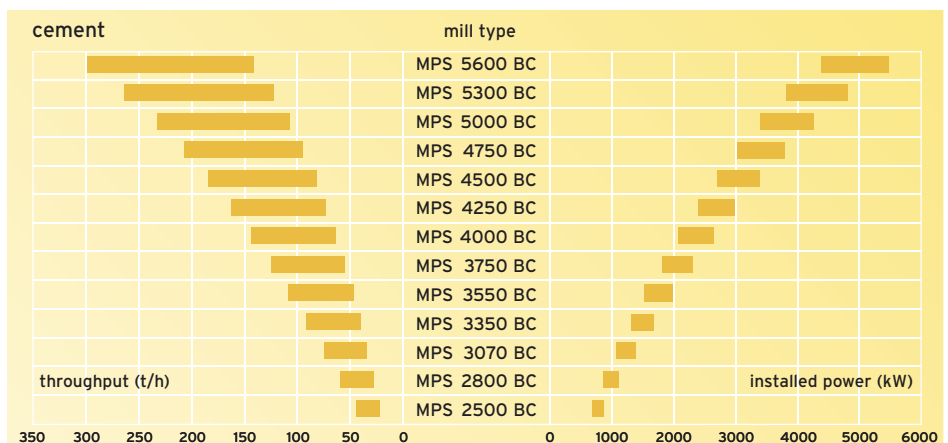
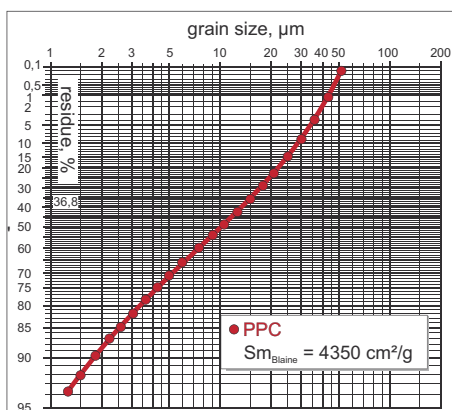
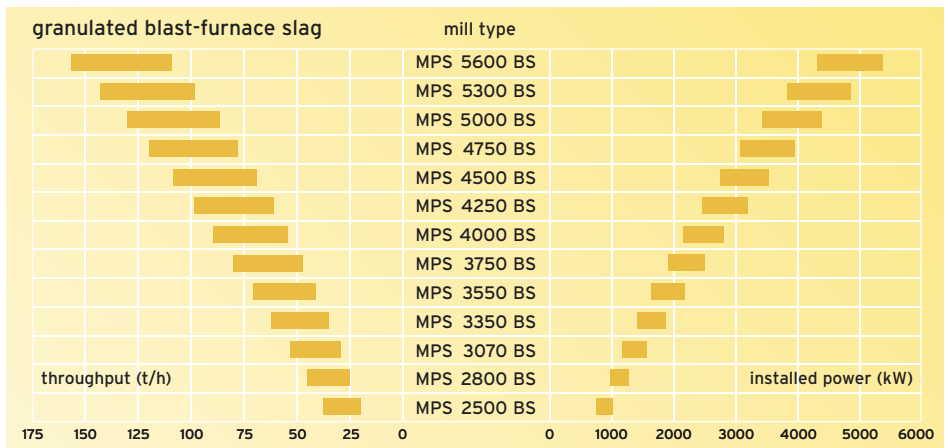
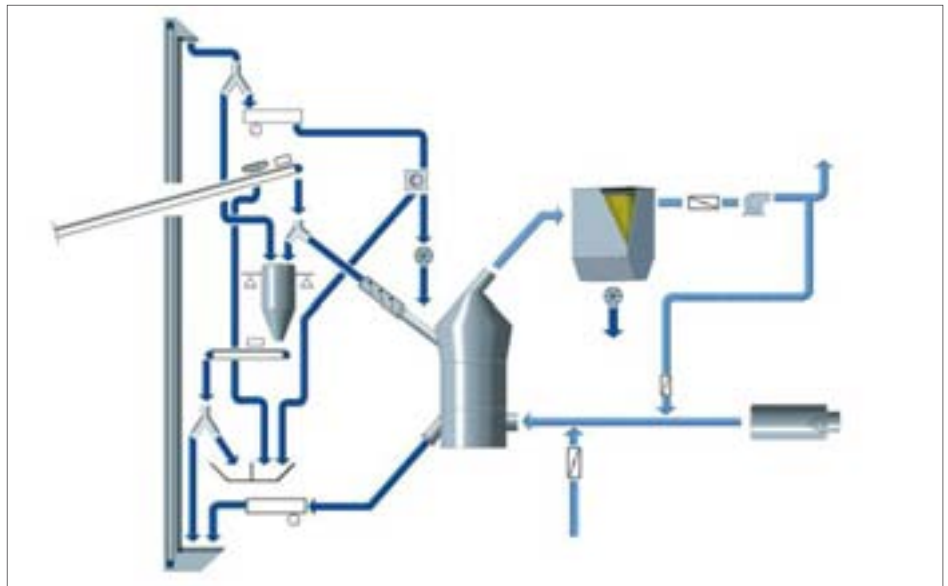





Wear protection Maintenance

Wear protection

Depending on the wear zones and abrasiveness of the material to be ground, our roller mills are lined with different wear materials. The grinding elements are mainly made of alloyed cast iron as per DIN 1695, hardfaced cast iron or composite materials with high-chromium inserts in ductile base materials. The housing and other mill components exposed to jet wear are protected by means of highly wear resistant steel plates or hardfaced composite steel plates. Components particularly exposed to jet wear, e.g. gas outlet ducts, are fitted with ceramic liners. Fast and easy replaceability is a major design feature.

MVR roller swing-out system

As with any roller mills, the wear parts of the grinding elements are exposed to the highest wear. On the MVR mill, it is very easy to replace or regenerate these grinding elements. In fact the MVR mill has a hydraulic system that allows to swing out the rollers in a controlled way, using the newly conceived roller suspension system, and to replace the one-part wear parts easily. The wear parts of the grinding plate are replaced with a lifting device and the maintenance drive.

The grinding rollers can be swung out separately, thus allowing the continuation of mill operation while doing maintenance work (active redundancy). The regeneration of wear parts can be done either inside or outside the mill.

The advantages

- active redundancy
- short downtime
- safe and easy handling of components
- only one hydraulic system for both mill operation and maintenance work



MPS Lift-and-Swing System

As with any roller mills, the wear parts of the grinding elements are exposed to the highest wear. Therefore it must be very easy to replace or regenerate them. With the proven Lift-and-Swing System, the wear parts can be replaced rapidly, using one single maintenance door. For this purpose, the grinding rollers and grinding bowl segments are moved in front of the maintenance door, using the maintenance drive, and are swung out of the grinding zone.

The advantages

- short downtime
- safe and easy handling
- only one maintenance door arranged for ease of access
- reduced space requirement

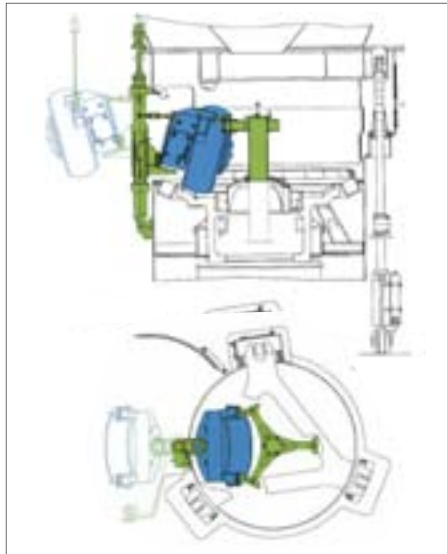

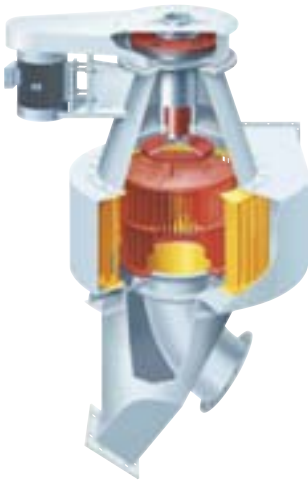

PFEIFFER SLV high-efficiency separator - the name for quality and economy

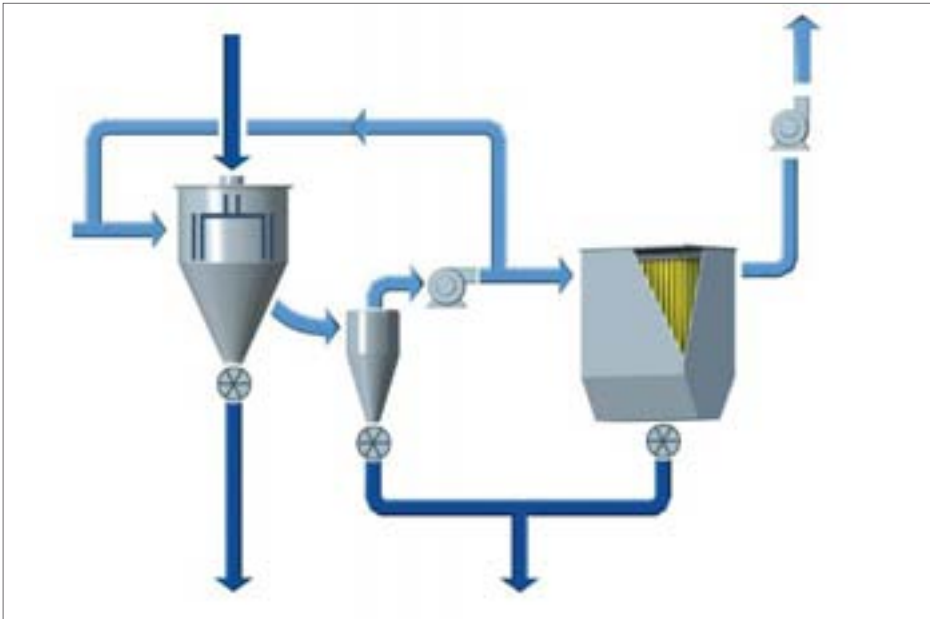

PFEIFFER SLV high-efficiency separator

The solution to your problem

separation of	bulk materials
feed rates	1 - 500 t/h
target fineness	10 - 90 μm

The working principle

Dispersed in the air stream, the material to be separated is conveyed to the separating zone where it is separated into fines and grits. The grits are evacuated through a cone for any further preparation. The fines are separated in a downstream cyclone or filter.

The advantages

Sharp separation

Uniform material distribution in the separating zone thanks to the central material feed.

Pre-separation and post-separation due to the optimum arrangement of the louver plates.

Diverse applications

SLV separators may be used for separation in one pass or in circuit operation with grinding plants.

Long service life

The special linings we commend for wear protection are made of steel, rubber, synthetic or ceramic materials depending on the type and abrasiveness of the material to be separated.

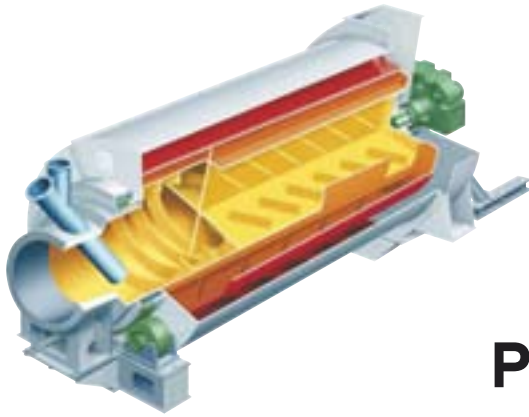

PFEIFFER Triplex dryer

The solution to your problem

Drying of bulk materials

production capacities	1 - 200 t/h
feed sizes up to	150 mm
any usual feed moisture	
residual moisture up to	0.1%

The working principle

The Triplex dryer type TRT operates on the co-current principle, i.e. material and hot gases flow in the same direction, passing through the dryer tubes from inside to outside.

Fed into the innermost tube of the dryer, the material passes through the dryer for being discharged through double-pendulum flaps fitted to the dust jacket.

The residual moisture of the product is controlled by setting the exhaust gas temperature and retention time in the dryer.

The hot gases are generated in a combustion chamber that may be fired with solid, fluid or gaseous fuels. Process exhaust gases may also be used.

Dust collection of the dryer exhaust gases is performed in a filter.



TRT Triplex dryer with hot gas generator

The advantages

Careful material treatment

Thanks to the co-current principle, the material cannot overheat.

Low thermal energy consumption

Minimum heat loss by radiation due to small dryer surface and co-current principle.

Reduced space requirement

Short construction length due to three-tube design, hence low capital cost for building and foundations.

Short starting and stopping times

Temperature resistant steel plate design instead of ceramic lining.



PFEIFFER services - you can always count on us



Test station

At our test station, raw materials are tested for their processing behavior. In our laboratories, we characterize them, considering applicable specifications and standards. The test station is equipped with pilot plants comprising machines from our production range for throughput rates from 0.5 to 10 t/h. The test results form the basis of our selecting the process and rating the machinery.

Consultancy

Our consultancy services comprise the design and planning of new plants and rebuilds, capacity increases and modernization of existing plants, maintenance and repair schedules, selection of appropriate wear materials as well as any process-related aspects.



Manufacture

Our own manufacturing facilities comprise mechanical workshops and a foundry. Every single manufacturing step is thoroughly planned and quality is supervised and documented systematically on the basis of the quality management system as per DIN ISO 9001.



Spare parts service

Original spare parts guarantee that your plant will operate economically even after many years after its installation. Our experienced specialists will be pleased to give advice. The wear analysis of the grinding elements, which is done electronically, records their actual state, ensuring maintenance and procurement as needed for the requirement.

Erection and commissioning

Experienced engineers and supervisors are available for supervision of erection and for commissioning as well as for the training of your attendance and maintenance personnel.



GEBR. PFEIFFER

Progress is our tradition

Gebr. Pfeiffer SE
Barbarossastraße 50-54
67655 Kaiserslautern/Germany
Phone: +49 631 4161 0
Fax: +49 631 4161 290
E-mail: kv-p@gpse.de
Internet: www.gpse.de